



***Advanced Applications that Enhance Business  
and Operational Processes in the Gas Pipeline  
Industry***

---

René Varón, Energy Solutions International  
Mike Bryant, Florida Gas Transmission

## VISION FOR THE GAS MARKET

During the past years the energy market has experienced an exponential increase in gas consumption creating a new market that includes hard to-predict and demanding requirements from the power generation industry. In the new market Gas Pipeline Transportation Companies need to know more accurately, in real time as well as ahead of time, the amount of capacity available and where it is located. However, what is available may not be accessible. Accessibility is a function of line-pack, compression and facility utilization. Therefore, it is critical to know accessibility for today, tomorrow and five days from now. This information is obtained by supporting the business processes with real time and predictive information on the pipeline, which in turn will allow the optimization of the operations parameters to match the needs of the business.

The integration offers a range of benefits including but not limited to:

- Matching availability to nominated gas
- Allowing operation of the pipeline closer to the maximum throughput
- Determining the ability to meet obligations
- Publication of capacity for sale
- Correctly allocating volumes to shippers
- Execution of short term transactions
- Developing new services
- Offering new opportunities for customer interaction
- Minimizing operational production costs

The main objective of this article is to present in a practical way the typical functionalities of the advanced applications for pipeline modeling and simulation, and how these tools have supported the daily operation of a pipeline transportation company like Florida Gas Transmission.

*Florida Gas Transmission* is a real case, using advanced applications, where it has been possible to increase sustainable deliveries by 4%. Florida Gas Transmission did this without any additional compression power or pipeline installation. At the same time, they were able to reduce operational costs, representing important additional revenue and savings to the company.

The current evolution of the global gas markets has required transportation companies to improve their procedures using real-time data to support their daily decisions. Efficiency and profitability pressure pipeline operators to go beyond the typical conservative operation. It is no longer possible for operations or gas control to simply keep the pipeline operating in an acceptable manner and be marginally profitable. Nor is it possible for business decision-makers to vaguely understand the value of the transport capacity that they may have for sale or the ability to move another MCF of gas through constraint points.

The Real Time modeling applications provide operators with accurate information to support their decision making process. Detailed pictures of the current available capacity at any point in the network as well as

possible impact of moving additional gas through the pipeline can be evaluated in advance with the use of the application tools.

To be successful today pipeline information and business data must be combined and synchronized to produce the greatest profit opportunity. The advanced applications need to be designed and implemented with a main goal of interaction between the business world and the operational world. To reach this goal requires following some basic concepts:

- **Integration** – A key concept in the implementation of advanced applications. Most natural gas pipeline companies have many legacy systems that cannot be replaced in their entirety in a short time frame. Having a legacy system means that the framework for any forward-looking system design must seamlessly blend the legacy system with new and future systems from multiple suppliers. It is not only integration with legacy systems but also with systems from different sources, SCADA, Real Time Modeling, EFM, with Nomination Packages, Backoffice tools, Marketing tools, etc. The information must flow from one application to the other in a coherent way, sharing relevant data between these two worlds.
- **Optimization** – Once both worlds have been integrated, it is required to optimize the operational process. At this point the goal that the company wants to achieve is clear and now it is time to define the best way to get there. Optimization tools for compressor units and line pack have an important role in the daily operation of the pipeline.

Once a communication-channel is established between the operational world and the business world, the system and all its advanced applications will become an administration tool for the optimization of the business' profits.

Traditionally, simulation tools have focused exclusively on the gas control operator or the planning group. Now, these tools focus on the entire corporation by making both the business and the operational data available. Depending on the type of market in which it is operating, the procedures that define the transportation business could change. Nevertheless, transportation in an open market follows determined outlines that facilitate and regulate the interaction between the transportation company and the shipper. This article does not pretend to establish business guidelines or rules. It is solely intended to present a vision of the information flow and how the advanced applications can support each one of the parties involved for proper decision making.

#### CYCLE OF THE TRANSPORTATION BUSINESS

There are three basic types of players in the current gas market:

- **Producers**
- **Transportation Companies** – operating gas pipelines.
- **Shippers** – This category includes all the gas buyers; such as the end users, the generator plants, the residential and industrial consumers, or the intermediary agents who purchase gas for resale.

These groups maintain continual communication that follows a specific protocol, which defines the basic cycle of the gas transportation business.

From the point of view of the transportation company, the sequence of events could be summarized as follows:

- Definition of the transportation service contracts
- Reception of the shippers' daily nomination
- Consolidation of nominations
- Contractual validation of the nominations
- Hydraulic validation of the nominations
- Generation of confirmations to the shippers
- Gas shipment
- Gas measuring
- Consolidation of account balances
- Invoicing

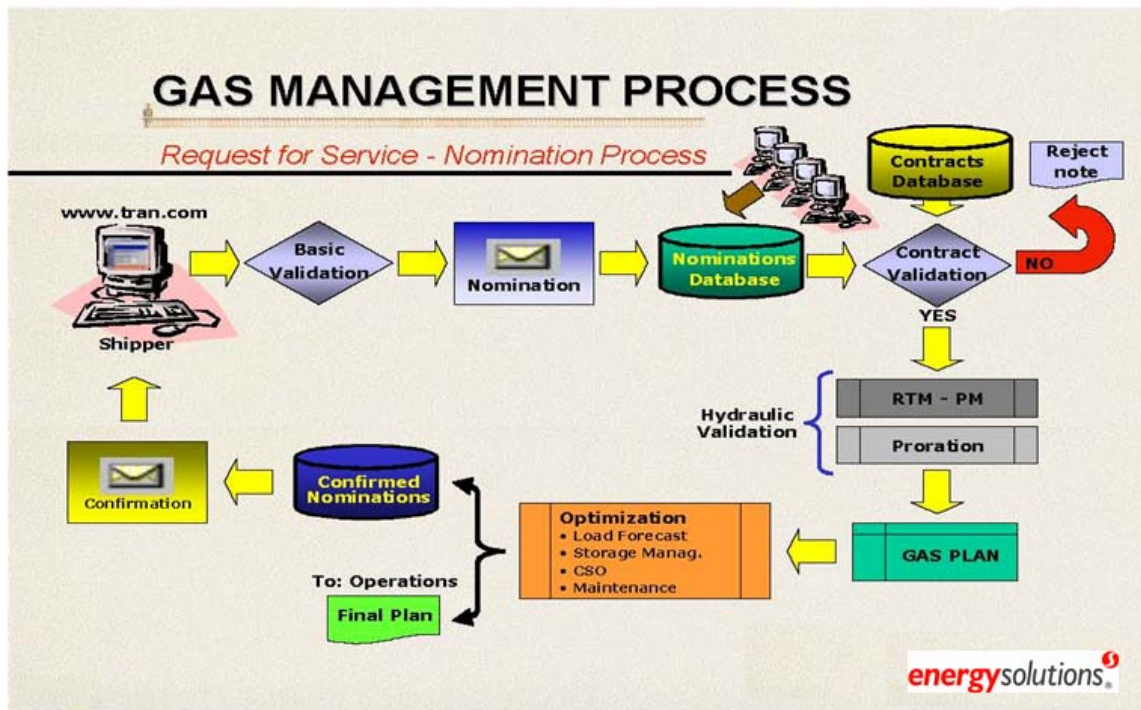

**FIGURE No. 1 NOMINATION PROCESS**

Each one of the activities listed above is the responsibility of a different division within the organization of the transportation company. Therefore, the flow of information should be coherent, fast and precise. Additionally, each one of the divisions should have the necessary tools to make the right decision at the right time.

Advanced applications play an important role in the development of transportation's daily activities. The operator of the control center, as well as the network administrator, must know, in detail, the current and future conditions of the system using as a point of reference the obligations already acquired. Additionally, it is very important to identify business opportunities, in other words available capacity to be offered to potential buyers. The applications that can provide the transportation company with these basic capabilities are: The Real Time Model, Predictive Model, and Look Ahead Model.

## **SUPPORT AND MANAGEMENT TOOLS**

### **THE NEW NATURAL GAS MARKET**

A new group of players has been created as a result of the current plan of gas market liberation. As the first step to establish the liberation process, it is necessary to separate each one of the activities related to exploration, transportation and distribution of natural gas. With this new plan, the producer will concentrate on producing and selling gas, the transportation company on transporting gas and selling its full pipeline capacity, and the distributor on providing services to the end users.

While the new work plan evolves, it becomes possible to develop secondary gas markets, in which third parties will have access to the purchase and sale of gas. These agents are known as Traders, Brokers or Intermediaries.

The implementation of this new work plan is lead by a regulatory agency that is in charge of protecting the interest of end-users as well as establishing regulations to guarantee a fair competition among the service suppliers. In general terms, the market is now wide open and the end users have the option to acquire gas, transportation and distribution services from different suppliers. The only difference for the users is the quality of the services.

### **CHARACTERISTICS OF THE NEW NATURAL GAS MARKET**

Having the new work plan as a reference point, the transportation companies and the producers face important challenges in their own businesses from both the operational and managerial points of view. These challenges are determined by the nature of the business and include the following aspects:

- The only asset of the transportation company now is its pipeline capacity. Therefore its main objective is to use it at maximum capacity, 24 hours a day, seven days a week.
- The producers have the commitment to manage their resources efficiently. Their main objective is selling their whole production under the best possible conditions established by the market place.
- The number of commercial transactions will increase radically. Nominations, validations and renominations for producers, distributors, industrial customers, intermediaries and other transportation companies must be processed in short periods of time and in a more efficient manner.
- At the same time the complexity of each one of the commercial transactions increases delivery of more accurate and updated information to the different destinations is expected. Daily account balances,

schedule balances, purchase order confirmations and the ability to receive new nominations to take advantage of production and/or capacity in use are the daily activities of producers and transportation companies.

- The effectiveness for the business development of the production and transportation companies is based on the ability of commercial decision-makers to consider the operational condition of the gas pipeline network as well as the production condition. Therefore, a complete integration between the business world and the operational world is mandatory.
- Faster, more reliable and efficient interaction with clients becomes the basic element of business. The availability and transfer of information between the supplier and the end-users is the key element to establishing an effective electronic commerce service to the clients.
- The business evolves continuously and the ability to offer new services, such as parking, lending storage options, and others allows the transportation companies to explore new business opportunities. In the same manner, the producer has the ability to establish new business calculations for future markets. This will become a new source of income, more complex and profitable.

## **STRUCTURE OF THE SOLUTION**

The solution to be implemented in order to face this new structure of business involves special functionalities, which are specifically defined by the type of business. Among the functionalities that the application requires are the following:

- A flexible and coherent integration between the new applications and the existing ones. The need for integration among the systems is very clear. Therefore, a dynamic and strengthened architecture is required to accomplish this integration.
- Ability to communicate with clients through an electronic commerce interaction.
- Ability to give administrative support to complex commercial transactions. Automated administration of documentation and processing of service purchase orders is necessary.
- Evolution of the operational processes and complete coordination with the commercial group. Appropriate transfer of information between departments. The solution provides support to the operational group as well as the commercial group by delivering correct and precise information to each one involved in the decision-making process.
- Safe sharing of information by following the outlines for access and encryption in the transfer of information
- A flexible solution to support the business evolution and the possible modifications that arise during the establishment and maturity of the market.

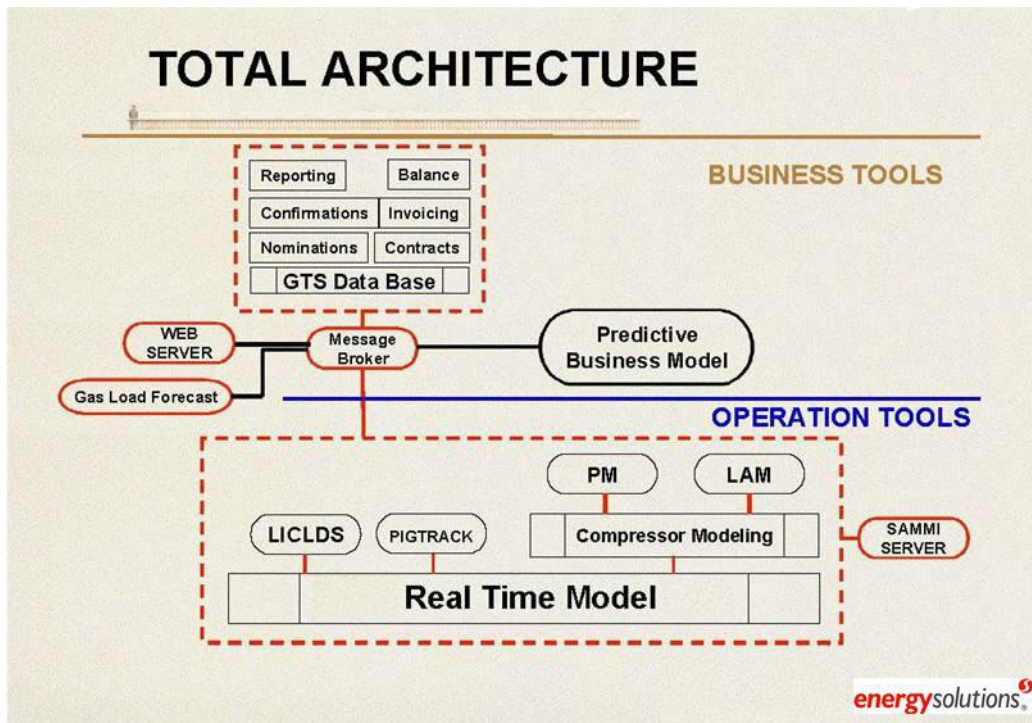

**FIGURE No. 1 – TOTAL SOLUTION**

**CONCLUSIONS**

A technical and commercial justification for the implementation of an automated solution for the management and processing of commercial transactions in a natural gas transportation network is clearly established. From the technical point of view, it is evident that the new business structure requires a solution that allows handling all information related to the business in a secure and coordinated manner.

From the commercial point of view, the justification is even more conclusive. In the new open-market structure, the transportation companies will be able to sell their services to a larger number of clients, such as end-users or intermediaries, only if they know the information in real time and can publish said information throughout a massive communication media such as the Internet. The basics of electronic commerce are to receive the product purchase order, to consolidate information of the orders received, to evaluate the ability to cover and confirm the orders, and to set closing dates according to the contractual conditions if required, and finally, to publish the capacity to be delivered at maximum production.

Commercially quantifying the advantages of implementing a system of this nature is a complex process since it relies on regulations that rule the business and the operational policies of each company. Nevertheless, it is very clear that throughout this work plan, the operational costs are reduced when the administrative process of the services or nominations purchase orders are automated and the business opportunities of the company increase by being able to specifically evaluate its position in regard to the commitments already acquired and its ability to comply with those commitments. Additionally, the company

can position itself in the eyes of its clients as the best option to provide on line services when accessing the information.

## **CASE STUDY – FLORIDA GAS TRANSMISSION**

The real-time dynamic pipeline model implemented by Energy Solutions for operation of the Florida Gas Transmission system has proven to be a tool that was and is instrumental in improving total system performance. This section primarily discusses the definition, implementation and application of modeling technology and the resulting achievements. The overall achievements and changes were achieved not in one quantum leap forward, but by small steps in the correct direction.

The case of Florida Gas Transmission shows concrete results from the investment return point of view, considering exclusively the operational aspect and the use of advanced tools to give support to the daily workload of the transportation companies. This particular case allows evaluating the advantages and it justified the investment of resources in the development of a project of such magnitude.

## **REAL TIME MODELING SYSTEMS**

The main objective of the real time modeling applications is to help the operators in their daily work improve the pipeline performance. It is very important to mention that the most useful applications for gas transportation systems are related to predictive capabilities, such as off-line models, look-Ahead model and “on-line” predictive models. Other applications for optimization purpose are frequently needed as well in this kind of networks.

The purpose of an on-line system is to provide information where the SCADA systems cannot due to lack of instrumented points to record and also allow the operator to see the pipeline’s future and provide a true picture of the pipeline. The pipeline modeling system and its advanced applications are tools to aid the operator in interpreting the past, evaluating the present and considering alternative ways of moving product and operating the pipeline in the future based on feasibility, desirability and cost.

The general concept of the model may be defined as a set of related procedures, which together define a process; in this case the process is the physical pipeline behavior. In order to represent this physical behavior, Energy Solutions has developed a sophisticated mathematical model for steady state and transients conditions, based on a group of factors such as the governing equations (Conservation of mass, Conservation of momentum, Energy equation, Equations of state), boundary conditions, and operation pipeline information. The model is completely dynamic with the ability to simulate any transient pipeline conditions.

One of the most important factors to evaluate to determine the performance of the modeling systems is the robustness, which refers to the system stability. The model’s equations mentioned above (conservation of

mass and momentum) are solved numerically in a fixed x-grid along the pipelines in order to ensure a high stability and excellent performance. In the solution, consideration is given for variations such as friction factor, thermal expandability, compressibility of fluid and pipeline, etc. This method improves the performance of the model, avoiding possible unstable situations. Using this method, the model is solved for each element of the pipeline network. Thus, if there is some unstable solution for one element in the network, this solution will not affect the overall model solution.

In order for a model to simulate the real world in a proper software application, it must contain a greater amount of detail than traditionally incorporated into engineering models. Basically, all functional operational details of the physical network and equipment must be modeled. The main purpose of this model is to provide a set of pressure/flow, composition (product property) and temperature profiles along the pipeline, which represent its physical behavior. Based on this information, the system processes all the calculated and received data to finally implement the advanced applications.

The key to the success of any software system is the use of well-proven, dependable software, which uses the latest available methods and contains the enhancements necessary to operate in the real world.

## **PREDICTIVE MODEL**

Based on the Real-Time model, the predictive model tool is a simulation facility capable of performing “What if?” scenarios. The predicative model provides the capability to simulate pipeline operational strategies independently without disturbing normal pipeline operations. The model utilizes any combination of measured, calculated or artificial process measurements or equipment statuses. It is executed in time steps and provides a simulation of pipeline conditions. This application is an excellent tool for engineering, planning purposes.

## **LOOK AHEAD MODELING**

Based on the current status of the network, this tool provides forecasting of near future pipeline conditions. The look ahead tool performs a faster-than-real-time forced-flow analysis to discover the consequences of controlled adjustments, independent but based on real-time pipeline operations. In addition this applications uses the information related to nominations gathered from shippers, to evaluate if some pressure constrain will be violated due to the current consumption and the remained capacity requested by the shipper.

## **FLORIDA GAS TRANSMISSION NETWORK**

With approximately 5,000 miles of pipe and 300,000 horsepower on the system, the Florida Gas Transmission pipeline has a delivery capacity of approximately 1,650MMcf/d of natural gas per day. The Florida Gas system is characterized by the pipeline’s dynamic swings in line pack caused by delivering the majority of its gas to electric generation power plants. Unlike other North American pipelines, the system’s peak deliveries are during the summer to meet cooling loads.

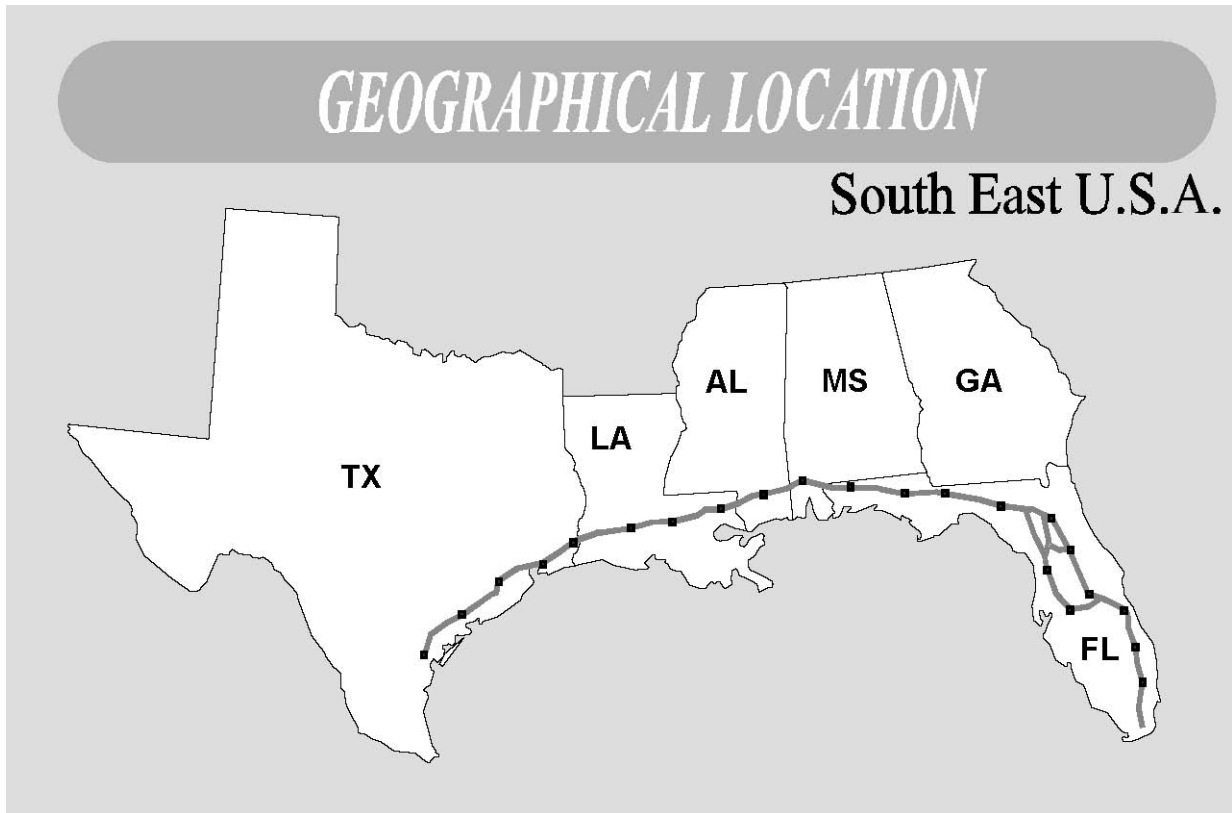

**FIGURE No. 2 – FLORIDA GAS PIPELINE**

#### BUILDING AND IMPLEMENTING A PIPELINE MODEL

The modeling project began shortly after Florida Gas increased its delivery capacity of the pipeline from 925MMCF/day to 1460 MMCF/day. Overall system complexity increased with the addition of a parallel third line operating at higher pressure and operating with turbine compressors instead of the traditional reciprocating compressors. Furthermore, Florida Gas' pipeline has no market area storage, but still faces the challenge of a high load factor market with a large percentage of the market customers using gas to meet electric generation peaking loads. Due to the increase in delivery capacity and the challenging market demands, Florida Gas decided to build a real-time transient model to give those who operate the pipeline on a day-to-day basis a tool to assist in meeting the challenges of operating a fairly difficult pipeline.

Engineering or off-line simulation models have been successfully used for many years; however, in the past real-time or on-line dynamic models have proven to be fairly difficult to successfully implement. Florida Gas found success in its real-time model by first having the gas control department build and use the model to manage every day problems and outages encountered on the pipeline before attempting to use the model to optimize the system.

Following is an approximate timeline of the implementation of the Energy Solutions model, the related events, & the related improvements:

- March 1995 - Expansion of pipeline capacity to 1460 MMCF/d completed. The decision was made to proceed with the selection of a real-time model vendor.
- March 1996 – Florida Gas decides to model the market and receipt portion of the pipeline and all operational modes of each compressor stations.
- September 1996 - Modeling project completed.
- December 1996 - Model is used to help with outage coordination effort of several major pipeline jobs.
- January 1997 - Model proves to be helpful in determining how to configure portions of pipeline in preparation for smart pig runs.
- February 1997 - Model is used to determine more fuel-efficient operational modes for winter operations.
- May 1997 -- Model used as a tool to analyze how to optimize horsepower configurations to improve overall throughput.
- July 1997 - As a result of model studies, the operational modes of several compressor stations are changed. Market deliveries are increased 2% above previous levels.
- September 1997 - Increased effort using model to determine how overall fuel usage could be reduced.
- April 1998 - Increased effort using model to determine how to further increase total throughput and reliability.
- June 1998 - With the combination of compressor station and linepack management optimization, throughput is increased another 2% while at the same time increasing total system reliability. Significant fuel usage reduction also achieved.
- October 1998 - Development begins on the model to create a gas control trainer.
- January 1999 - Yearly total fuel usage charge to market area customers for 1998 shows a 12% reduction compared to previous years.
- February 1999 - Gas control trainer is completed.
- July 1999 – More peak day record deliveries are achieved with continued stable and reliable service provided system wide.
- September 1999 – Florida customers show great interest in Florida Gas' Phase IV expansion.
- January 2000 – Florida Gas' Real-time model is enhanced by including Phase IV facilities. Optimization flow studies begin to compare current load patterns with capabilities of upcoming facilities.
- March 2000 – Florida customers show great interest in Florida Gas' Phase V expansion.
- January 2001 – Florida Gas' Real-time model is enhanced by including Phase V facilities. Optimization flow studies begin to compare current load patterns with capabilities of upcoming facilities.
- April 2001 – Phase IV pipeline expansion completed.
- August 2001 – Optimization efforts contribute to incremental record deliveries. Fuel usage levels are kept below design conditions.

#### USAGE OF MODEL ON A DAY TO DAY BASIS

The Energy Solutions model is used virtually everyday as part of the effort to manage the Florida Gas system. The model's usage ranges from the relatively simple gathering of data to meet a data request, to determining how to optimize a portion of the overall system while facing a unique operational situation.

Following is an approximation of what percent of time the real-time model is used in gas control for each of these different functions:

- Outage Coordination (50%) - The model is used the greatest percentage of time to determine how to most efficiently operate the pipeline during horsepower and/or pipeline segment outages. Flow studies are primarily run to test different operational configurations to determine the positives and negatives of each configuration. After selecting the best operational configuration, the model is used to determine how much throughput is affected so that the pipeline can be scheduled appropriately. Frequently in the past an overly cautious restriction was placed on the market because of the lack of ability to study the impact that an outage would have.
- SCADA Error and Problem Resolution (15%) - On a day-to-day basis the model often indicates that the SCADA system is reporting information that is contradictory to reality. The Florida Gas SCADA system monitors and receives information from over 24,000 individual points. The model can provide assistance primarily with pressure, flow, and condition of state SCADA points. The model cannot know which SCADA point is sending in false information; however, the model can determine that a set of SCADA point readings cannot exist at the same time. The model has indicators along the pipeline that will let the user know when there is an indication that some error exists. The model will also indicate that a physical condition in the pipe is not as is reported. This is particularly helpful with regulators and valves that do not have SCADA measurement. The model has oftentimes shown that a problem exists, and after first investigating whether SCADA measurement was working, the physical states of valves and regulators were checked. The model has been particularly helpful in determining when regulators have drifted significantly from their intended setpoint.
- Flow Studies for Pigging (5%) - Smart pigging allows for the gathering of critical pipeline data and is a routine part of the operation of the Florida Gas system. Smart pigs require that they move down the pipeline at speeds ranging between 4 to 6 miles per hour. If the pig's speed deviates significantly, then the data gathered becomes unreliable, and another smart pig run is necessary along with the additional cost of each smart pig run.
- Improved overall system performance studies - 10%
- Operational data gathering for third parties - 10%
- Gas control training - 10%

The model is used to determine the horsepower configuration that should be used for all the stations in the region surrounding the pigging operation. Once a configuration is chosen that will provide the most stable flow conditions for the smart pig, then the receipts and deliveries are scheduled in accordance with the planned configuration.

#### BUILDING CREDIBILITY

During 1996 and 1997 as the model was successfully used to better coordinate outages, an overall confidence in the model was established. This confidence was critical in the graduation of the model to being used as an “optimizer”. After this credibility was established, the model began to be used as a tool to start studying how to optimize individual compressor stations and the entire system from an overall throughput, fuel usage, and reliability standpoint.

If the users of the model had attempted to try to first undertake the challenge of optimizing total throughput and total fuel usage, then there would have been no track record to build on. Without a successful performance history for a tool, there will probably not be enough organizational support to implement change.

#### COMPRESSOR STATION OPTIMIZATION

- *Complex Compressor Station Modeling* -The majority of the functionality at each compressor station is modeled in Florida Gas' model. This allows the user of the model to test almost every operational mode at each of the compressor stations. Several of our compressor stations have the ability to be operated in many different operational modes including a few stations that can operate in just under 100 different operational modes. The ability to test these stations in modes that have never been used before has proven to be invaluable considering that it is not reasonable to do an actual physical test at compressor stations that are vital in maintaining delivery pressures to large customer sites.
- *Individual Compressor Station Optimization* – Florida Gas' compressor Station 19 serves as an example of one of the stations that was optimized after using the model to analyze operations. Figure 2 shows a diagram of this fairly complex station. This station has the ability to isolate compressor units to individual lines, and in total the station can have 50+ operational modes. This station was previously operated with one unit isolated to one of the individual lines. Seven of our largest customer's electric generation stations are located downstream of Station 19. Flow studies were run to determine how to maximize flow and discharge pressure at Station 19 to increase deliveries to these customer sites. After testing the station's modes of operation, two important conclusions were drawn: first, that a more optimal mode of operation should be implemented; and secondly, that a regulator needed to be added to enable a specific pressure to be maintained on the 26" suction line.

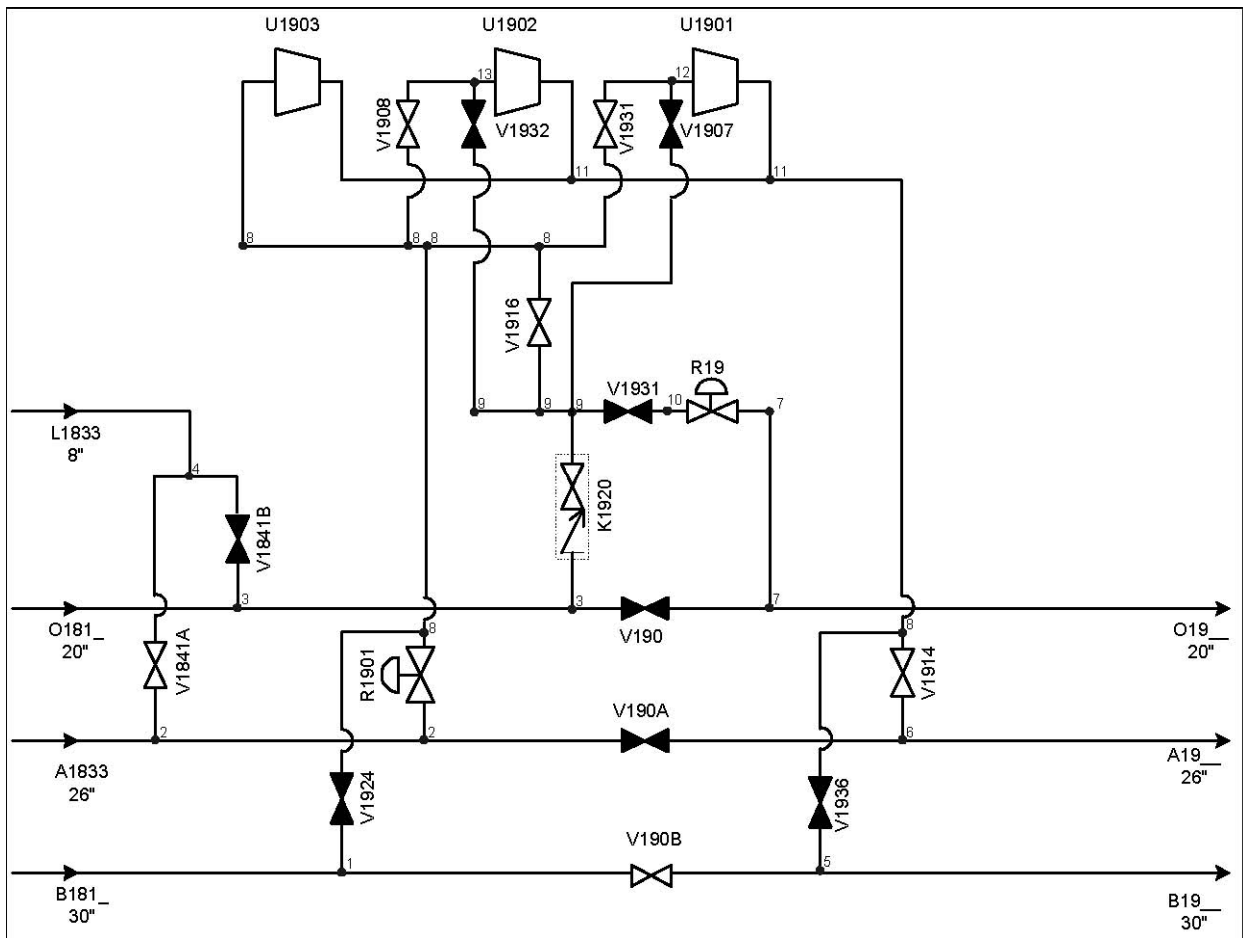

**FIGURE 3 - STATION 19**

Improving the operations of critical compressor stations and realizing the physical performance improvements was one of the significant steps toward justifying the cost and effort put into building the model. Implementing advanced technology is always challenging; however, achieving physical results that justify the modeling project has always been Florida Gas' goal.

#### OVERALL MARKET DELIVERY INCREASES

In addition to the studies that were conducted at individual compressor stations, the model was used to study how to best configure all market area horsepower, valving, and regulation. While the flow studies for Station 19 showed how to increase deliveries downstream of Station 19, the larger perspective market flow studies showed that more gas could be flowed into the entire market place if a grouping of compressor stations were jointly configured in an optimal throughput position for a larger percentage of the day (at night one of these stations needed to be operated for a different set of parameters). Furthermore, flow studies indicated that only a certain quantity of gas should be scheduled into specific regions of our market. This seems somewhat obvious that only certain quantities should be scheduled downstream of compressor

stations; however, when gas can flow in either direction in large "loop" sections of a pipeline then scheduled delivery targets become much more critical.

Florida Gas was able to increase sustainable deliveries by 2% within one year of completion of the model. In addition to delivering more gas into the entire market as a result of optimization, Florida Gas also encountered fewer delivery pressure problems at customer sites, which in the past had experienced pressure problems that resulted from committing to more gas than was possible to customer regions.

#### LINEPACK MANAGEMENT

In the fall of 1997 many flow studies were done to determine how to minimize fuel usage. Flow studies were concentrated on how compressor station optimization and linepack management affect fuel usage performance. It was determined that by optimizing horsepower configurations and maintaining specific line-pack levels in different regions of the pipeline that throughput could be maximized and fuel could be minimized. Also from flow studies there was indication that optimal line-pack conditions significantly varied as total market demand varied and that optimal horsepower configurations varied as linepack varied. Recommendations were developed to propose how to more efficiently manage linepack levels (Florida Gas is a pipeline that has no storage facilities). Managing total linepack seems as though it should be relatively simple; however total linepack is affected on a day-to-day basis by many difficult to control factors including the following:

- Market area overburns
- Market area underburns
- Receipt area overdeliveries
- Receipt area underdeliveries
- Actual fuel usage differing from the fuel retention rate
- Gas losses due to pipeline maintenance or repair
- Gas losses due to unaccounted for activity

Total line-pack can be managed by the following activities:

- Scheduling market area payback to reduce imbalances
- Scheduling receipt area payback to reduce imbalances
- Buying gas for injection into line-pack
- Selling gas for withdrawal from line-pack
- Limiting market overburns/underburns via financial penalties for noncompliance
- Moving gas into or out of line-pack as a result of Florida Gas' "Park & Ride" service

(note: Florida Gas' "Park & Ride" service allows customers and marketers to pay for the right to inject (Park) gas into linepack without a corresponding delivery that day or withdraw (Ride) gas from linepack without a corresponding receipt of gas that day.) The above-mentioned linepack activities are managed by a well-coordinated effort involving several departments within Florida Gas.

**RECORD DELIVERIES – JUNE 1998 & AUGUST 2001**

Florida Gas was able to significantly increase sustainable deliveries as the result of optimizing the operations of several key compressor stations and by proactively managing linepack to maintain linepack at optimal operating conditions. The previously accepted maximum sustainable delivery into the market was 1475 MMCF/day by June of 1998, a new sustainable maximum was achieved – 1525 MMCF/d. The optimization of compressor stations was the most critical element. The second most critical factor to increasing throughput was managing line-pack to maintain optimum levels.

Flow studies and a review of the compressor performance curves show that individual compressors perform several percentage points better as conditions approach optimum suction and discharge pressures. When line-pack is maintained at optimum levels across the entire pipeline the entire pipeline performs several percentage points better. The same optimization methods were again used on the Florida Gas system after the Phase IV expansion facilities were installed. By August 2001, Florida Gas was again able to deliver incremental volumes above originally designed levels.

**INCREASE OF CAPACITY - FGT**

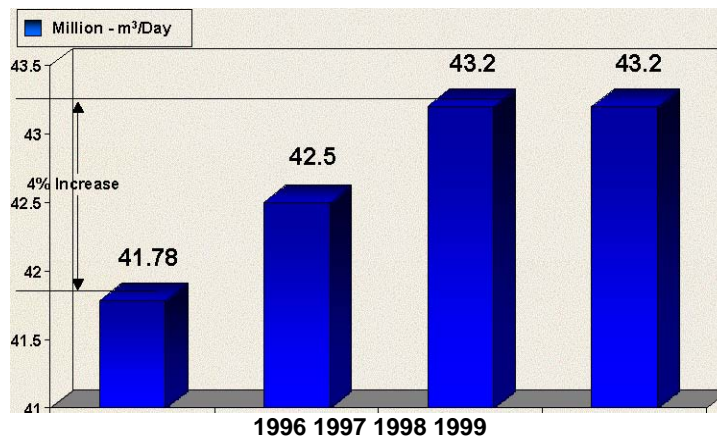

**FIGURE 4 – RECORD DELIVERIES**

**RELIABILITY IMPROVEMENTS**

One of the additional benefits to optimizing linepack levels and horsepower configurations is that customers benefit with improved overall reliability in maintaining delivery pressures during times of maximum deliveries. As the result of optimal horsepower configurations at target linepack levels, Florida Gas has made using the service provided as easy as possible for the customers. Physical pipeline performance improvements have

allowed our customers to experience better pressures which in turn results in Florida Gas allowing more overburn/underburn flexibility.

#### OVERALL FUEL USAGE REDUCTION

Florida Gas was able to significantly reduce its total fuel usage as the result of optimization. According to the Florida Gas tariff, fuel costs are paid by the customer; thus, Florida Gas is improving customer service and competitiveness by reducing the cost of the service provided.

From 1996 to 1998, the fuel rate charged to the customer was reduced 12% as indicated in Table 1. This resulted in an estimated savings of \$3,500,000 to our customers for 1998. The operational mode of some compressor stations was changed in 1997, and some forms of proactive linepack management were also started. The linepack management process was fully implemented in 1998 along with additional compressor station optimization. For 1999 the average fuel rate was brought down to 2.77% which resulted in a total estimated saving of \$5,000,000 per year compared to previous years.

As new Phase IV expansion facilities have been installed on the Florida Gas system, the same optimization methods again have been used to ensure that our fuel rate stays low so that the cost of our service remains as competitive as possible for our customers.

## REDUCTION OF FUEL USAGE - FGT

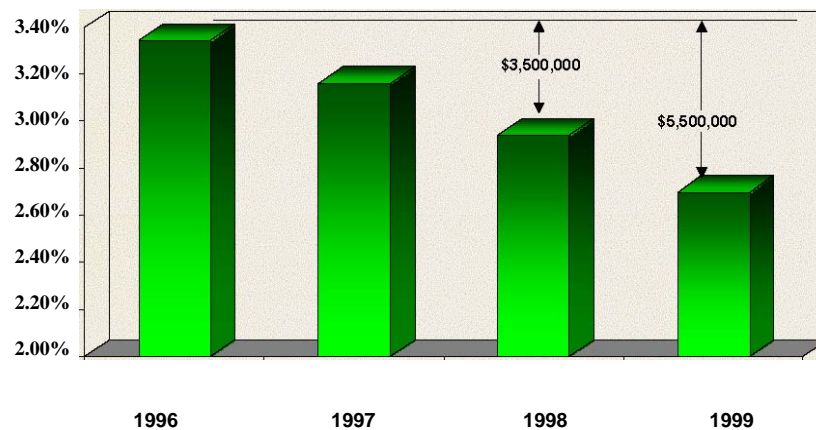

**FIGURE 5 – REDUCTION OF FUEL USAGE**